

CHARNWOOD COUNTRY 4 MKII

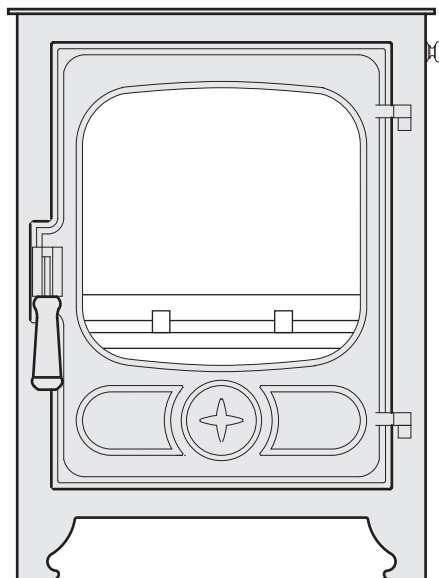

Operating and Installation Instructions



CHARNWOOD

Country 4 MKII

Operating and Installation

Instructions

Contents

Operating Instructions

Fuel	2
Fitting The Riddling Grate	2
Lighting	2
Controlling The Fire	2
Refuelling	3
Ash Clearance	3
Low Burning	3
Cleaning and Maintenance	3
Throat plate & Flueway Cleaning	3
Chimney Sweeping	3
Servicing	3
Trouble Shooting	3

Installation Instructions

Health & Safety Precautions	5
Specification	5
Chimney	5
Hearth and Fire Surround	5
Connections to flues	5
Soot Doors	5
Pre Lighting Check	6
Commissioning	6



CHARNWOOD COUNTRY 4 MKII

OPERATING INSTRUCTIONS

Before lighting the stove check with the installer that the work and checks described in the Installation Instructions have been carried out correctly and that the chimney has been swept, is sound and free from any obstructions. The stove is not suitable for use in a shared flue system. It is suitable for intermittent operation.

FUEL

This stove has been designated to burn wood. Only dry well seasoned wood should be burnt on this appliance as burning wet unseasoned wood will give rise to heavy tar deposits in the stove, on the glass and within the chimney. For the same reason hard woods (such as Ash, Beech and Oak) are better than soft woods (such as Pine and Spruce.) Burning wet unseasoned wood will also result in considerably reduced outputs. The wood should be cut and split and then left to season in a well ventilated dry place for at least one year but preferably two years before use.

PETROLEUM COKE IS NOT SUITABLE FOR USE ON THIS APPLIANCE. ITS USE WILL INVALIDATE THE GUARANTEE.

For advice on other fuels please contact Charnwood.

Wood should not be burnt in smoke controlled areas.

FITTING THE RIDDLING GRATE

Tool required for fitting the riddling grate:

1 - 10mm Spanner

1 - Phillips screwdriver

Before fitting the riddling grate remove the fuel retainer and the wood ash retainer. The wood ash retainer is not required when the riddling grate is fitted.

Undo the nut on the riddling blanking hole using a 10mm spanner. Remove the cover and spacing washer (ensure you keep these in a safe place as you will need to replace them if the riddling grate is removed).

Feed the riddler rod through the hole on the right hand side of the stove, and slide one washer onto the rod, (if there is not

sufficient room to the right of the stove to do this then remove the riddler knob, fit one washer over the rod and then slide the rod through the hole from the inside of the stove.)

Feed the rod through the two side fireplates and slide the other washer on to the rod so that the washers end up outside the two side fireplates. With the side fireplates pushed together fit the retaining clips so that the washers come inside the clips.

Slide the side fireplates apart so that they rest against the sides of the firebox. Slot in the front and rear support plates.

Fit the grate plates into position through the front and rear grate support plates, making sure they locate correctly onto the riddler rod. Fit the fuel retainer. Slide the ashpan under the grate.

LIGHTING

On initial lighting, the stove may smoke and give off an odour as the silicon paint with which the firebox is painted reacts to the heat. This is normal and will cease after a short time, but meanwhile the room should be kept well ventilated.

At first only light a small fire and burn it slowly for two hours to allow any residual moisture in the chimney to evaporate.

The stove may be lit using dry kindling wood and paper or fire lighters. Place the

paper, or fire lighters, and kindling on the base or the grate and cover with a thin layer of fuel. Open the spin wheel in the door and open the airwash control fully (see Fig. 1). Light the paper or fire lighters. Close the door until the fuel is well ignited then load with fuel and adjust the air controls to the required setting.

When relighting the stove, leave the ash on the base if burning wood, unless it is becoming too deep, in which case some of it may be removed. If burning high ash content fuel, clear the grate and empty the ashpan before relighting.

CONTROLLING THE FIRE

The rate of burning and hence the output is controlled by the spin wheel and the airwash control (see Fig. 1).

The spin wheel should only be used when lighting or when rapid burning is required. It should not be left fully open for long periods as this can cause over-firing. For low burning it should be closed.

The airwash control is used most of the time to control the burning rate and to keep the glass clean. Fully extended gives full airwash for faster burning and clean glass whereas fully closed gives low burning. It will not be possible to keep the glass clean if this control is fully closed, particularly

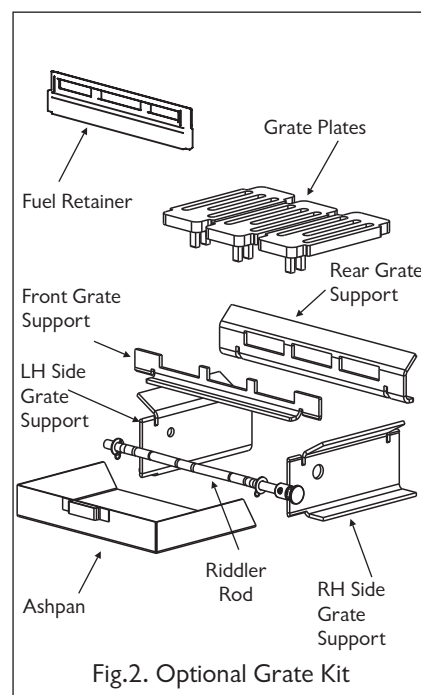
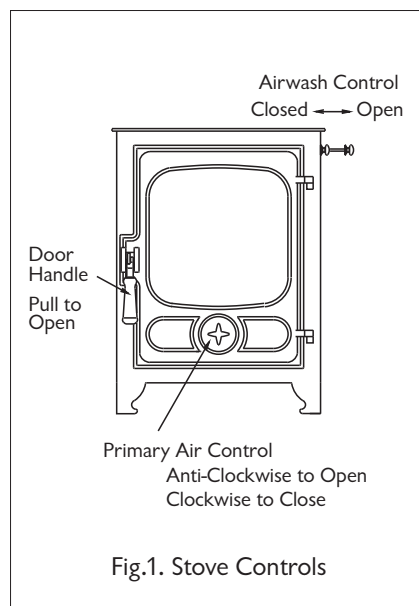

immediately after refuelling.

When the stove is hot, these controls must only be operated using the tool provided or a glove to avoid the danger of burned fingers.

REFUELLING

Keep the firebox well filled but do not allow fuel to spill over the top of the fuel retainer.

Care should be taken, especially when burning wood, that fuel does not project over the fuel retainer or damage to the glass may be caused when the door is closed, it can also cause the glass to black up. Typical refuelling interval when running the stove at rated output burning logs is 1.5 hours. Maximum filling height is such that logs cannot fall from the fire when the doors are opened. Liquid fuels are not to be used on this appliance.

ASH CLEARANCE

The ashpan should be emptied regularly before it becomes too full. Never allow the ash to accumulate in the ashpan so that it comes in contact with the underside of the grate as this will seriously damage the grate bars. The ashpan is handled using the tool provided. Care should be taken to ensure that ash is cool before emptying it into plastic liners or bins.

To make ash removal easier there is a special Charnwood ash carrier available. This may be purchased from your supplier or, in case of difficulty, from ourselves.

LOW BURNING

For reduced burning the fire door must be closed.

When burning wood load some large logs

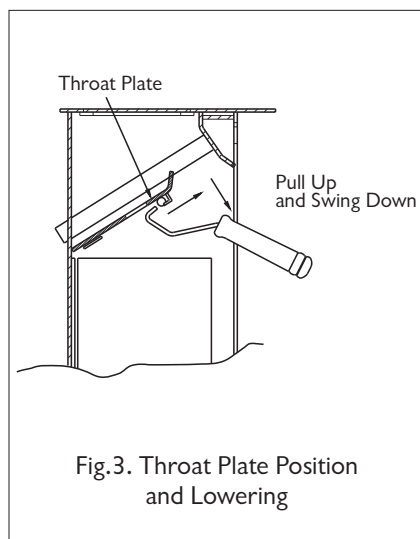

Fig.3. Throat Plate Position and Lowering

on the fire and allow to burn for half an hour before closing the spin wheel, (this will help to reduce tar deposits in the chimney.) Leave the airwash control slightly open to help keep the glass clear. Some experimentation may be necessary to find the setting most suitable for the type of fuel being used and the draw on the chimney.

To revive the fire, empty the ashpan, (if burning fuel other than wood), riddle the fire, and open the air controls to maximum. When the fire is burning well load on more fuel as necessary and adjust the air controls to the desired setting.

CLEANING AND MAINTENANCE

The stove is finished with a high temperature paint which will withstand the temperatures encountered in normal use. This may be cleaned with a damp lint-free cloth when the stove is cold. Should re-painting become necessary, high temperature paints are available from your supplier or from stove shops.

Most deposits on the glass may be burnt off simply by running the fire at a fast rate for a few minutes. If it becomes necessary to clean the glass then open the door and allow it to cool. Clean the glass using a damp cloth and then wiping over with a dry cloth. Any stubborn deposits on the glass may be removed with a proprietary stove glass cleaner or ceramic hob cleaner. Do not use abrasive cleaners or pads as these can scratch the surface which will weaken the glass and cause premature failure

THROAT PLATE AND FLUEWAY CLEANING

It is important that the throat plate and all the stove flueways are kept clean in order to prevent potentially dangerous fume emission. They should be cleaned at least monthly, and more frequently if necessary. It is not necessary to let the fire out to carry out these operations.

The front of the throat plate is pulled forward and then lowered as shown in Fig. 3. Any sooty deposits should then be swept from the plate and into the fire.

Return the throat plate to its correct position - raise the front of the plate, push it back and then lower it onto the retaining lugs.

CHIMNEY SWEEPING

The chimney should be swept at least twice a year. Where the top outlet or vertical rear flue connector is used it will generally be possible to sweep the chimney through the appliance.

First remove the fuel retainer and the throat plate. Then sweep the chimney ensuring that soot is removed from all horizontal surfaces after sweeping.

In situations where it is not possible to sweep through the appliance the installer will have provided alternative means, such as a soot door. After sweeping the chimney the appliance flue outlet and the flue pipe connecting the stove to the chimney must be cleaned with a flue brush.

After clearing any soot from within the stove, replace the throat plate (see Fig. 3.) and the fuel retainer.

Different types of sweep's brushes are available to suit different flueways. For standard brick chimneys a wire centre sweep's brush fitted with a guide wheel is recommended. For prefabricated insulated chimneys the manufacturers instructions with regard to sweeping should be consulted.

SERVICING

It is recommended that the fire is serviced once a year to keep it in first class working order. After cleaning out the firebox thoroughly, check that all internal parts are in good working order, replacing any parts that are beginning to show signs of wear. Check that the doors seals are in good condition and that the door seals correctly. A servicing guide is available on request. Repairs or modifications may only be carried out by the Manufacturer or their approved agents. Use only genuine Charnwood replacement parts.

TROUBLE SHOOTING

Fire Will Not Burn.

Check that:

- a) the air inlet is not obstructed in any way,
- b) chimneys and flueways are clear,
- c) that a suitable fuel is being used,
- d) that there is an adequate air supply into the room,
- e) that an extractor fan is not fitted in the same room as the stove.
- f) there is sufficient draw in the chimney.

Once the chimney is warm a draught

reading of at least 2.5 mm (0.10 inches) water gauge (25Pa) should be obtained.

Door Glass Blacks Up

Differences in chimney draughts mean that the best settings of the air controls will vary for different installations. A certain amount of experimentation may be required, however the following points should be noted and with a little care should enable the glass to be kept clean in most situations:

- a) Wet or unseasoned wood, or logs overhanging the front fence will cause the glass to blacken.
- b) The airwash relies on a supply of heated air to keep the glass clean, therefore, when lighting the stove allow the firebed to become well established before closing the spin wheel. This may also be necessary when re-fuelling the stove.
- c) When re-fuelling keep the fuel as far back from the front fence as possible, do not try to fit too much fuel into the firebox.
- d) Never completely close the airwash control - as a guide it should be at least a quarter open.
- e) The spin wheel may be kept slightly open to assist in keeping the glass clean.

It is always more difficult to keep the glass clean when running the stove very slowly for long periods.

If blackening of the glass still occurs check that all flue connections and the blanking plate are well sealed. It is also important

that the chimney draw is sufficient and that it is not affected by down-draught.. When the chimney is warm a draught reading of at least 2.5 mm (0.10 inches) water gauge (25Pa) should be obtained.

Some blackening of the glass may occur below the level of the coal retainer. This will not obscure the view of the fire or affect its performance.

Fume Emission.

Warning Note:

Properly installed and operated this appliance will not emit fumes. Occasional fume from de-ashing and re-fuelling may occur. Persistent fume emission is potentially dangerous and must not be tolerated. If fume emission does persist, then the following immediate actions should be taken:

- a) **Open doors and windows to ventilate the room.**
- b) **Let the fire out and safely dispose of the fuel from the appliance.**
- c) **Check for flue or chimney blockage, and clean if required.**
- d) **Do not attempt to re-light the fire until cause of fume has been identified, if necessary seek professional advice.**

The most common cause of fume emission is flueway or chimney blockage. For your own safety these must be kept clean.

Fire blazing out of control

Check that :

- a) The door is tightly closed.
- b) The spin wheel is fully closed.
- c) The airwash control is closed.
- d) A suitable fuel is being used.
- e) Door seals and airwash slide are intact.

Chimney Fires.

If the chimney is thoroughly and regularly swept, chimney fires should not occur. However, if a chimney fire does occur close the spin wheel and the airwash control, and tightly close the door of the appliance. This should cause chimney fire to go out which case the controls should be kept closed until the stove has gone out. The chimney and flueways should then be cleaned. If the chimney fire does not go out when the above action is taken then the fire brigade should be called immediately.

After a chimney fire the chimney should be carefully examined for any damage. Expert advice should be sought if necessary.

CHARNWOOD COUNTRY 4 MKII INSTALLATION INSTRUCTIONS

HEALTH AND SAFETY PRECAUTIONS

Please take care when installing the stove that the requirements of the Health and Safety at Work Act 1974 are met.

Some types of fire cement are caustic and should not be allowed to come into contact with the skin. In case of contact wash with plenty of water.

If there is a possibility of disturbing any asbestos in the course of installation then please use appropriate protective equipment.

There must not be an extractor fan fitted in the same room as the stove as this can cause the appliance to emit fumes into the room.

As the output is below 5kW a permanent air supply is not normally required. This stove is capable of intermittent operation.

This stove is not suitable for use in a shared flue system.

In addition to these instructions the requirements of BS.8303 and BS.6461 Pt 1&2; 1984 must be fulfilled. Local Authority Bylaws and Building Regulations, including those referring to national and European Standards, regarding the installation of Solid Fuel burning appliances, flues and chimneys must also be observed.

SPECIFICATION

The nominal output of the Country 4 is 4.0 kW (13,600 Btu/h). This output is based on a 1.5 hourly re-fuelling cycle burning seasoned hardwood logs. The average flue temperature at rated output is 210°C. The Flue gas mass flow is 3.7g/s and the stove weight is 62kg.

CHIMNEY

In order for the appliance to perform satisfactorily the chimney height must not be less than 4 metres measured vertically from the outlet of the stove to the top of the chimney. The internal dimensions of the chimney should preferably be 175 mm (7 inches) or 200mm (8 inches) either square or round and **MUST NOT BE LESS THAN**

125 mm (5 INCHES).

If an existing chimney is to be used it must be swept and checked, it must be in good condition, free from cracks and blockages, and should not have an excessive cross sectional area. If you find that the chimney is in poor condition then expert advice should be sought regarding the necessity of having the chimney lined. If it is found necessary to line the chimney then a lining suitable for Solid Fuel must be used.

If there is no existing chimney then a prefabricated block chimney or a twin walled insulated stainless steel flue to BS.4543 can be used either internally or externally. These chimneys must be fitted in accordance with the manufacturers instructions and Building Regulations.

Single wall flue pipe is suitable for connecting the stove to the chimney but is not suitable for using for the complete chimney.

If it is found that there is excessive draw in the chimney then a draught stabiliser should be fitted.

It is important that there is sufficient draw in the chimney and that the chimney does not suffer from down-draught. When the chimney is warm the draw should be not less than 2.5mm (0.10 inches) water gauge (25 Pa). If in doubt about the chimney seek expert advice.

HEARTH AND FIRE SURROUND

The stove must stand on a fireproof hearth and combustible materials must not be used in the construction of the fireplace unless adequately fireproofed in accordance with local building regulations. The hearth temperature can, in extreme conditions, exceed 100°C and therefore a constructional hearth is required. The positioning of the stove and the size of the hearth are governed by building regulations for Class 1 appliances. These building regulations state that the hearth must extend in front of the stove by at least 300mm (12 inches) and to the sides of the stove by at least 150mm (6 inches). If in doubt as to the positioning of the stove expert advice should be sought either from the supplier or the local building inspector.

The fireplace must allow good circulation of air around the appliance to ensure that maximum heat is transferred to the room and also to prevent the fireplace from overheating. A gap of 150mm (6 inches) each side and 300mm (12 inches) above the appliance should give sufficient air circulation. If a wooden mantelpiece or beam is used in the fireplace it should be a minimum of 460mm (18 inches), and preferably 600mm (24 inches) from the appliance. In some situations it may be necessary to shield the beam or mantelpiece to protect it.

In order for the fire to operate correctly and to allow for access, there must be an air gap behind the appliance of at least 75mm, but be aware that this distance will need to be greater in some cases to meet Building Regulation requirements.

CONNECTIONS TO FLUES

The stove must be connected to the flue using 125mm (5") i/d pipe. This may be stainless steel, cast iron, or thick wall steel pipe. Straight lengths of Charnwood Pipe to match the stove are available if required.

There are several ways of connecting the stove to the flue. These are illustrated in Figs. 5 to 8.

If the optional vertical rear flue connector is used then the chimney may be swept through the appliance.

Horizontal lengths of flue must be kept to a minimum and should not be more than 125mm (5 inches) long. The sealing face of the flue collar must be coated with fire cement before fixing to the body of the stove using the two screws provided. The blanking plate must be removed, sealed with fire cement and refitted, care being taken to ensure that the fold on the clamping plate is in line with the lugs on the firebox as shown in Fig.4. Ensure that the clamping plate does not prevent the throat plate from seating correctly. All flue connections must be well sealed.

SOOT DOORS

It is possible to pass a 16 inch diameter sweeps brush through the appliance but in

most back outlet installations it will be necessary to have a soot door to enable the chimney to be swept. The optional vertical rear flue connector does allow the chimney to be swept through the stove.

Soot doors may either be in the actual brickwork of the chimney or in the register plate. Various positions of soot doors are shown in Figs. 5 to 8.

PRE LIGHTING CHECK

Ensure that the throat plate is fitted in the roof of the appliance. The location and positioning of the throat plate is shown in Fig. 3.

Check that the front fence is fitted correctly and that the door closes properly.

COMMISSIONING

On completion of the installation allow a suitable period of time for the fire cement and mortar to dry out before lighting the fire. If no grate is fitted make a layer of ash or sand on the base of the stove before lighting. Check to ensure that smoke and fumes are taken from the appliance up the chimney and emitted safely. Also check all joints and seals. On completion of the installation and commissioning please leave the operating instructions with the customer and advise them on the use of the appliance.

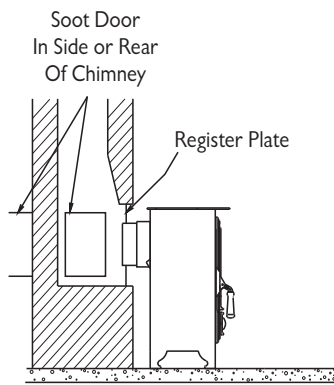
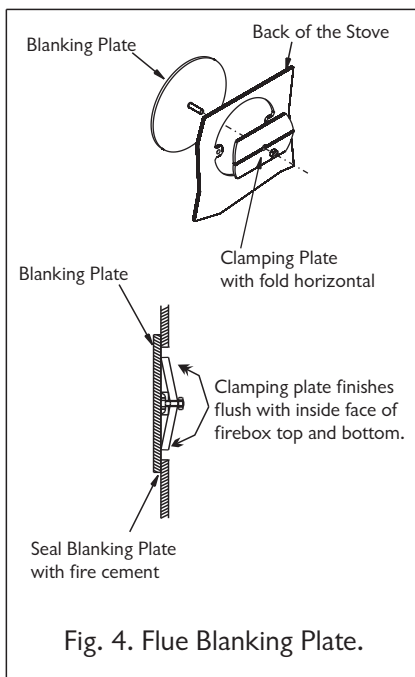

Fig. 5. Vertical Register Plate With Bricked Up Fireplace

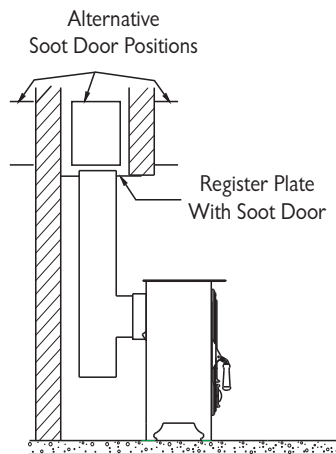

Fig. 6. Horizontal Register Plate With Rear Flue Connection

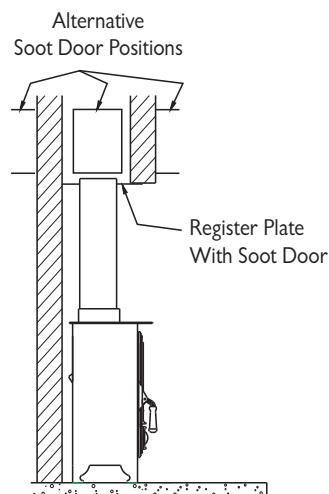

Fig. 7. Horizontal Register Plate With Top Flue Connection

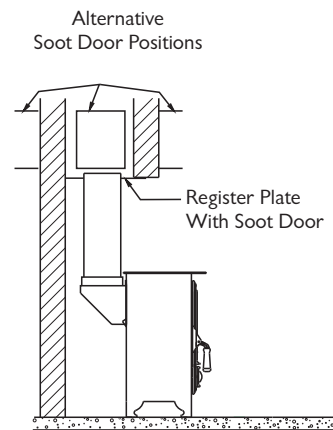
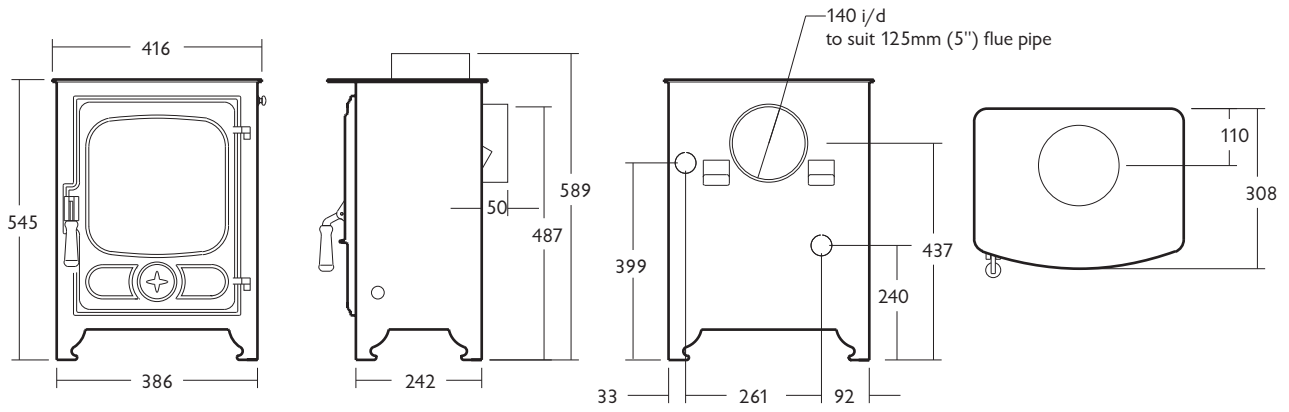
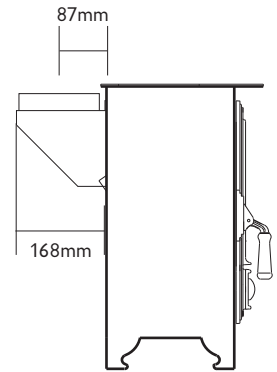

Fig. 8. Horizontal Register Plate With Optional Vertical Rear Flue Connector



Dimensions of the
Optional Vertical
Rear Flue Connector



Overall Dimensions
(All dimensions are in mm)

Charnwood Country 4 MkII

Parts List

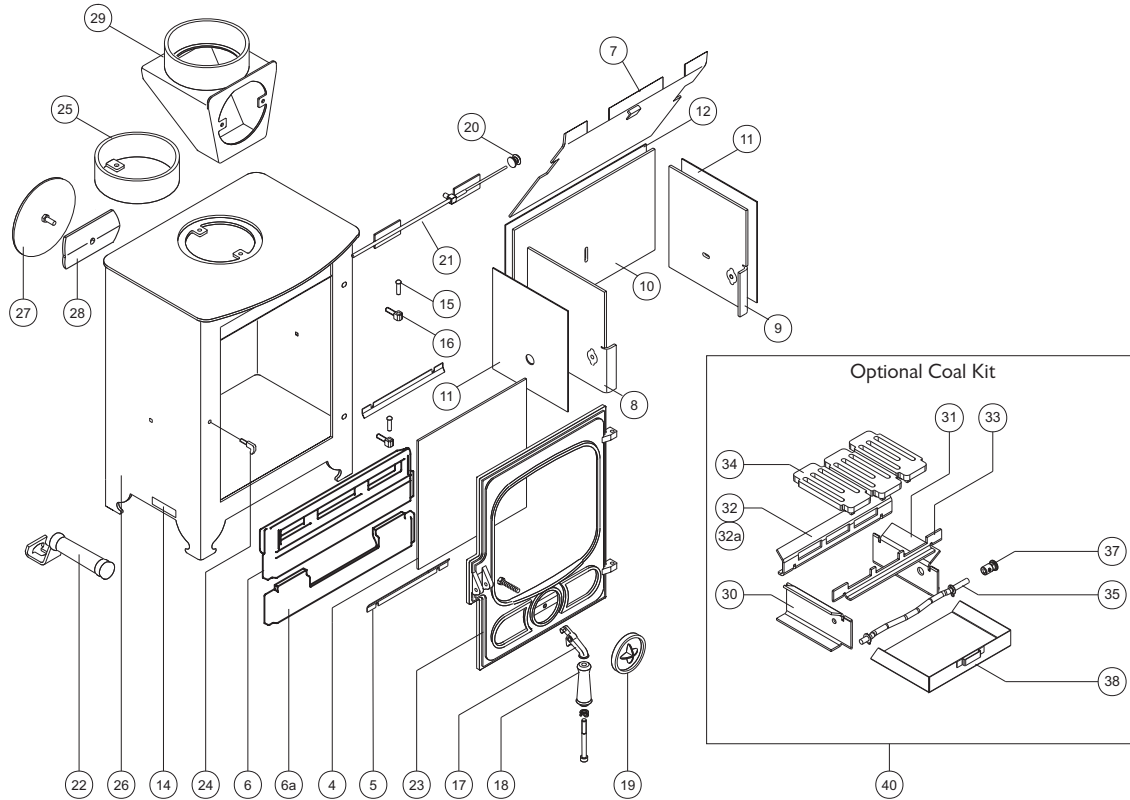

Item	Part No	Description	Item	Part No	Description
1*	008/PV21	Door Seal	26	001/EY10	Firebox (Country 4 MkII)
2*	008/FW29	Door Seal Adhesive	27	012/PV09	Blanking Plate
3*	008/PV23	Glass Seal	28	012/EY51	Clamping Plate
4	006/PV19	Glass (Inc Seal)	29	010/PV33	Vert. Rear Flue Adapter (Opt'l Extra)
5	004/BW23	Glass Retainer	30	010/EY04	Left hand Side Grate Support
6	002/EY23	Fuel Retainer	31	010/EY05	Right hand Side Grate Support
6a	002/EY24	Wood Ash Retainer	32	010/EY09	Rear Grate Support
7	010/PV31	Throat Plate	32a	010/EY06B	Rear Grate Support (Use with boiler)
8	010/EY15L	L.H. Side Fire Plate	33	010/EY06	Front Grate Support
9	010/EY15R	R.H. Side Fire Plate	34	002/EY03	Grate Plate
10	010/EY16	Back Fire Plate	35	010/EY13	Riddler Rod
11	011/PV26	Side Ceramic Gasket	36*	008/DY23	Riddler Rod Retaining Clips (pack of 10)
12	011/PV27	Back Ceramic Gasket	37	002/DY21	Riddler Knob
13	008/EY29	Set of Fire Plates(3) & Gaskets	38	004/PV17	Ashpan
14	012/PV11	Serial No. Label	40	010/EY20	Multifuel Kit (Optional Extra)
15	008/PV28/S	Hinge Pin Set (2 per set)	41*	010/EW51	Ash Carrier (Optional Extra)
16	008/FW28	Hinge Post	42*	010/PV35	Boiler, Steel (Optional Extra)
17	002/PV03	Door Catch Lever	43*	010/PV35/SS	Boiler, Stainless Steel (Opt'l Extra)
18	008/PV08	Door Handle (Incl. Screw & Washer)	44*	004/DY22	Riddler Blanking Disc
19	002/PV02	Primary Air Control			
20	002/TW13	Air Control Knob			
21	004/EY48	Airwash Slide			
22	012/BV20/A	Ashpan / Door Opening Tool			
23	002/PV01	Door			
24	002/PV13	Door Latch Hook			
25	002/PV12B	Flue Collar			

* These items are not shown on the drawing.



To obtain spare parts please contact your local stockist giving Model, Part No. and Description. In case of difficulty contact the manufacturer at the address shown.
This drawing is for identification purposes only.



CHARNWOOD - A.J.Wells & Sons Ltd.

Bishops Way, Newport, Isle of Wight PO30 5WS, United Kingdom



A Division of A.J.Wells & Sons Limited Registered in England No. 03809371

06

EN13240:2001

Country 4 Roomheater fired by solid fuel

EC Certificate of Conformity no.	:	EY44-CPD-2006
Combustible materials used in fireplace construction	:	No
Emission of CO in combustion products	:	0.89%
Flue gas temperature	:	201°C
Space heating thermal output	:	4.7kW
Energy efficiency	:	81.2%
Fuel types	:	Wood Logs

Your Local Charnwood Dealer:



CHARNWOOD Bishops Way, Newport, Isle of Wight PO30 5WS, United Kingdom

T:+44 (0)1983 537799 F:+44 (0)1983 537788 charnwood@ajwells.co.uk www.charnwood.com

A Division of A.J.Wells & Sons Limited Registered in England No. 03809371